

▶ **납품 실적 / Customer List**



PROJECT	
Hynix 반도체(주) Hynix Semiconductors	청주 M11 Hook-Up (MF Coating 납품) Cheongju M11 Hook-Up (MF Coating delivery)
LG 디스플레이(주) LG Display	파주 ASSET In-Let V/V Paju ASSET In-Let V/V
삼성전자(주) 아산탕정공장 Asan Tangjeong Plant, Samsung Electronics	IN-LET V/V 납품 IN-LET V/V delivered
매그나칩 반도체(유) MagnaChip Semiconductors	A1-Joint Coating 납품 A1-Joint Coating pipe laying construction
Hynix 반도체(주) Hynix Semiconductors	- 청주 M8, M9, M11 Hook-Up (A1-Joint Coating 납품) - 이천 M10 Hook-Up (A1-Joint Coating 납품) - Cheongju M8, M9, M11 Hook-Up (A1-Joint Coating pipe laying construction) - Icheon M10 Hook-Up (A1-Joint Coating pipe laying construction)
LG 디스플레이(주) LG Display	구미 P6, P8 H-Vacuum In-Let V/V Gumi P6, P8 H-Vacuum In-Let V/V
매그나칩 반도체(유) MagnaChip Semiconductors	IF-5, SR-1 Hook-Up (A1-Joint Coating 납품) IF-5, SR-1 Hook-Up (A1-Joint Coating pipe laying)
Hynix 반도체(주) Hynix Semiconductors	- 청주 M8, M9, M11 Hook-Up (A1-Joint Coating 납품) - 이천 M10 Hook-Up (A1-Joint Coating 납품) - Cheongju M8, M9, M11 Hook-Up (A1-Joint Coating pipe laying) - Icheon M10 Hook-Up (A1-Joint Coating pipe laying)
매그나칩 반도체(유) MagnaChip Semiconductors	F-5, SR-1 Hook-Up (A1-Joint Coating 납품) F-5, SR-1 Hook-Up (A1-Joint Coating pipe laying)
LG 디스플레이(주) LG Display	구미 P6, P8 H-Vacuum In-Let V/V Gumi P6, P8 H-Vacuum In-Let V/V
매그나칩 반도체(유) MagnaChip Semiconductors	A1-Joint Coating 납품 A1-Joint Coating pipe laying
넥솔론 Nexolon	익산공장 증축공사 H-Vacuum In-Let V/V Iksan plant expansion H-Vacuum In-Let V/V
웅진 코웨이 Woongjin Coway	대전공장 H-Vacuum In-Let V/V Daejeon plant H-Vacuum In-Let V/V
삼성전자(주) Samsung Electronics	탕정지구 T8-Project Hook-Up 납품 Tangjeong Area T8-Project Hook-Up pipe laying



본사 & 공장  
Main office & Factory  
충북 청원군 남이면 가마길 49-21 Tel. 043-213-2546 / Fax. 043-213-9118  
49-21, Gama-Gil, Nami-Myeon, Cheongwon - gun, ChungCheongBuk - do,  
Republic of Korea Tel. +82-43-213-2546 / Fax. +82-43-213-9118



Best Technology of LCD & Semiconductor

# ASSEMBLY JOINT

Assemble Joint Product Introduction



www.에스아이텍.com

# Company Information



## 회사소개 / Company Introduction

에스아이텍(주)는 반도체, LCD, BIO 등 배관설비시공 업체로 시작하여 Clean Room utility, 진공배관, 부식 Gas 배기 등 많은 Project를 성공적으로 수행하고 이를 기반으로 많은 연구개발 투자로 기존 제품의 단점을 개선하여 에스아이텍(주)만의 특화된 자재를 생산공급 및 시공하고 있습니다.

S-I TECH Co.,Ltd., starting as a constructor of plumbing fixtures of semiconductor, LCD, BIO etc., has performed successfully many projects such as Clean Room utility, vacuum piping, corrosion gas discharge, and produces and supplies its own specialized materials along with construction of them through improvement of past products by a great deal of investment in R&D based on much experience.

· 회사명	에스아이텍(주)	· Company Name	: S-I-TAEK CO., LTD
· 설립년도	1997년	· Establishment	: 1997
· 대표이사	최종석	· Name of Representative	: Jong Seok, Choi
· 사업자등록번호	315-81-31684	· Business Registration Number	: 315-81-31684
· 업태	건설업, 제조, 도매	· Business Kind	: Construction, Manufacturing, Wholesale
· 종목	반도체장비, 설비공사, 플랜트공사	· Type of Business	: Semiconductor Equipment, Facilities, Plant Construction
· 본사 및 공장	충북 청원군 남이면 가마길 49-21	· Main Office & Plant	: #49-21, Gama-Gil, Nami-Myeon, Cheongwon - gun, ChungCheongBuk - do, Republic of Korea
· 대표전화	Tel 043-213-2546 / Fax 043-213-9118	· Main telephone	: Tel +82-43-213-2546 / Fax +82-43-213-9118

## 회사연혁 / Company history

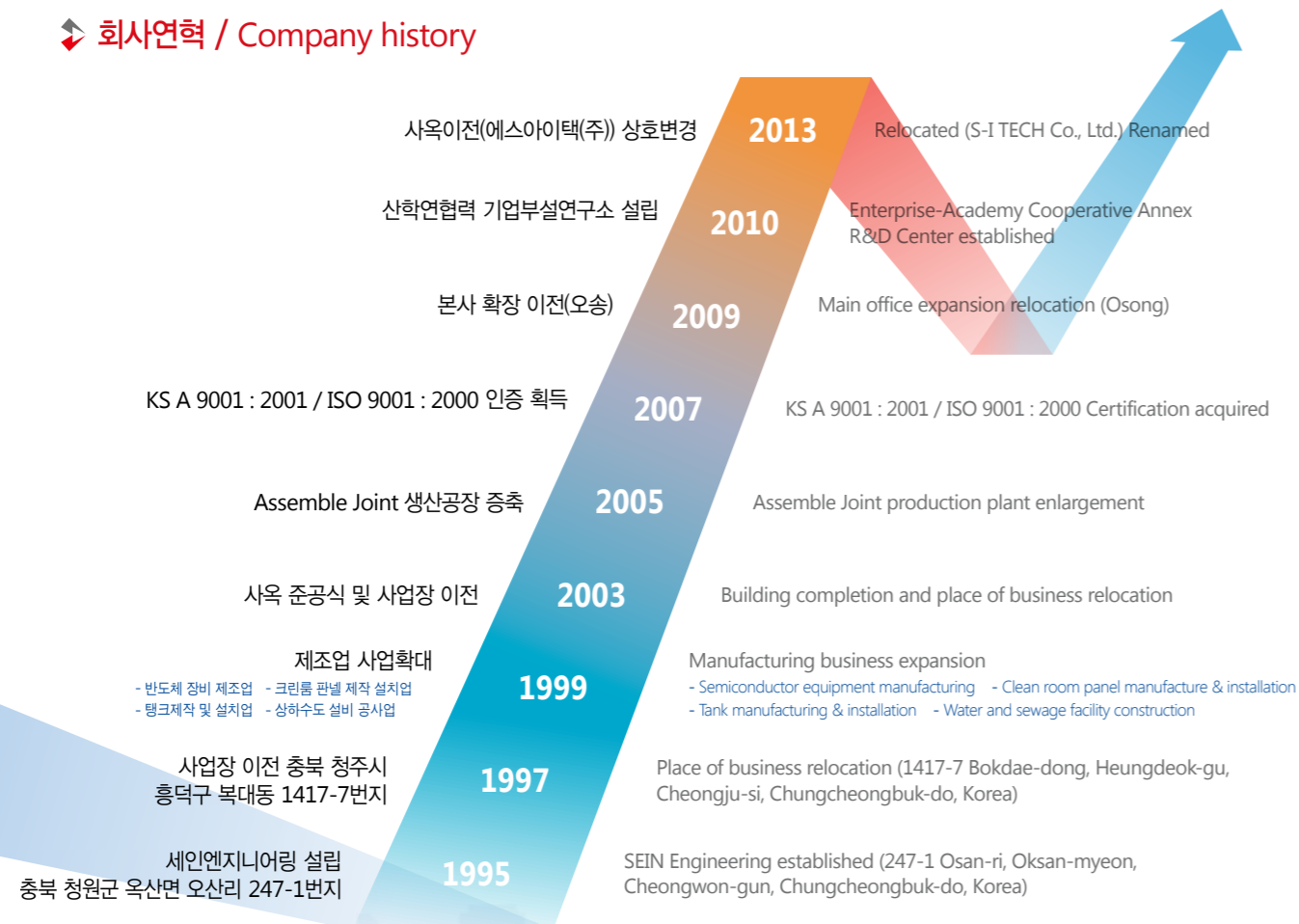

# PATENT / CERTIFICATES



## 특허증 / Patent



## 인증서 / Certificates



# Characteristics and Effects



## 소개 / Introduction

현재 반도체, LCD, 식품, 화학 설비 등 사용되는 Flange(NW, MF, DC)는 Pipe와 Welding하여 Bolting 체결하는 방식으로 화재의 위험이 있으며 공사 기간이 길어 비용손실이 발생되고 있습니다. 또한 Leak로 인한 진공손실로 장비와 에너지의 비용이 발생하여 현재 각사의 화두가 되고 있습니다. 당사 제품은 기존제품의 문제점들을 개선하여 진공손실을 줄이고 장비의 진동을 최소화하며 Pipe의 절단만으로 시공이 가능하므로 원가절감의 효과는 물론 모든 자재의 재사용이 가능합니다.

Flange (NW, MF, DC) which are currently used as parts of semiconductor, LCD, food, chemical equipment has a risk to ignite fire because it is manufactured by welding and bolting pipes. In addition, it is likely to bring about loss of costs due to a long construction period and to raise costs of equipment and energy because of vacuum loss accompanied by leaking. The problems are hot issues of every company. Our products improve problems of current products, decrease vacuum loss and minimize vibration of equipment. It is available to apply to construction by just cutting a pipe. Our products can reduce costs and be reused.

## 특징 및 효과 / Characteristics and Effects



### 3대 특징 / 3 Characteristics

- 무 용 접 : 화기작업/ 용접기/ Purge Line 不必要
- 무 가 공 : Cutter의 不必要
- 조립식공법 : Spool 제작/ 가조립 不必要 고능력 기능공 不必要(배관사, 용접사)

- 1) No welding : Heatless work/ Welding machine/ Purge line unnecessary.
- 2) No processing : Cutter unnecessary.
- 3) Assembly method : Spool manufacturing/ Temporary assembly unnecessary/ Highly qualified technician unnecessary-(plumber, welder).

### 5대 효과 / 5 Effects

- 공 기 단 축 : 시공방법 간결/ 작업 동선 단거리/ 작업 준비물 간결
- 원 가 절 감 : PM 주기 연장/ 생산 장비 가동연장/ 초기 SET-UP
- 비화기작업 : 화재 불안 無/ 인화성 TIE-IN 완벽/ 화기 감시자 無
- 품 질 향 상 : 우수한 기밀성/ 내진 효과/ 진동 흡수
- 재 사 용 : Modify 대처/ Revision 대처/ 세정후 70% 재사용

- 1) Construction time shortened : Concise construction technique/ Short work distance/ Concise job readiness.
- 2) Cost reduction : PM cycle extension/ Extended production gear running time/ Initial set-up.
- 3) No heat required : No apprehension of fires/ Complete inflammability TIE-IN/ No personnel required to monitor heat.
- 4) Quality improvements : Excellent sealing/ Earthquake proof/ Vibration absorption.
- 5) Reusable : Modification capable/ Revision capable/ 70% reusable after wash.

# The difference between current method



## 현 공법 비교 분석 / Comparative Analysis of current method

구 분	현행 공법(Welding + Flange)	신 공법(Assemble Joint)	STD Spec.
Diagram			<ul style="list-style-type: none"> <li>■ 최대 사용압력 Maximum operating pressure → 10 kgf/cm<sup>2</sup></li> <li>■ 진공 최대 도달압력 Vacuum maximum pressure → 초고진공 (10<sup>-8</sup> Pa), (10<sup>-10</sup> Torr) → Ultra-high vacuum (10<sup>-8</sup> Pa), (10<sup>-10</sup> Torr)</li> </ul>
Concept	SHOP : 제작 시간이 길다. SHOP : Production time is long.	Module 화된 제품을 조립 시공함 Assembling and construction of modularized productse.	<ul style="list-style-type: none"> <li>■ 内 Chemical → Free (See the tableproperties)</li> </ul>
Merit		<ul style="list-style-type: none"> <li>· 공기 단축으로 조기 Set-Up!!</li> <li>· 원가절감 및 비 화기작업의 안정성 확보!!</li> <li>· Shortened construction time enables earlier Set-Up!!</li> <li>· Cost savings, job safety with no-fire!!</li> </ul>	<ul style="list-style-type: none"> <li>■ Limit Of Application → By User</li> </ul>
Demerit	<ul style="list-style-type: none"> <li>· 많은 용접 Point로 투자비 상승</li> <li>· 시공시간이 길고 효율적인 공사가 힘들다.</li> <li>· 현장 제작으로(100%) 품질 관리 어렵다.</li> <li>· Revision 대처가 힘들다.</li> <li>· Joint 개소는 적지만 Leak가 많다.</li> </ul>	<ul style="list-style-type: none"> <li>· Rising investment cost because of many welding points</li> <li>· Construction time is long and efficient work is difficult to do.</li> <li>· On-site fabrication(100%) makes quality control difficult.</li> <li>· Revision is hard to deal with.</li> <li>· Fewer joint points but noticeable leakage.</li> </ul>	<ul style="list-style-type: none"> <li>STD. : Vacuum Exhaust Toxic Exhaust Heat Exhaust Organic Exhaust Chemical Drain</li> </ul>

## 현 공법 차이점 / The difference the current method

구 분(Division)	차이점(Difference)	효과 분석(Effects analysis)	
원가 Cost	현 공법 Current process 자재 재사용이 어렵다. 용접에 의한 원가상승 It is difficult to reuse materials.	100%	재 사용 시 추가적인 원가 절감 In re-use, additional cost savings
	신 공법 New method 자재 재사용으로 원가절감 극대화 Maximizing cost reduction through reuse of materials.	50% 최대 50%절감 Reduction up to 50%	
공기 Construction period	현 공법 Current process Spool이 크고 용접이 많아 공사기간이 길다 Construction period is long because of large spools and many melding points.	100%	현행공기 대비 2.9배 단축 2.9 times reduced construction period compared to the current period
	신 공법 New method 조립식으로 파격적인 공기 단축 Dramatic reduction of construction period with prefabrication.	34% Shortened Shortening up to 66%	
품질 Quality	현 공법 Current process Joint Leak 및 Fab 오염가중, C-Ring 내부 돌출부로 유체흐름 방해 Joint Leak and Fab contamination weighted, C-Ring internal projections interfere with the fluid flow.	현장제작 On-site production	Leak 제거 유체흐름 최적 Optimal fluid flow through removal of leaks
	신 공법 New method Fab 오염 제거 및 부식 방지 관내 돌출부 제거로 유체흐름 최적화 Fab decontamination and removal of corrosion-resistant projecting parts in tube leads to fluid flow.	고품질 유지 High quality maintenance	
안전 Safety	현 공법 Current process 용접중에 많은 산업재해 발생. 복잡한 공정으로 재해에 노출됨 Many industrial accidents occur during welding. Exposed to disaster because of complex processes.	복잡한 공정 Complicated process	인화성 작업 불필요 Toughening work isn't needed
	신 공법 New method 화재 및 산업재해 발생원인 제거 Removal of causes of fire and industrial accidents.	인원 대비 감소 Comparatively reduced personnel	
환경 Environment	현 공법 Current process 용접중에 다량의 유해물질 발생 재 사용이 어렵다 Re-use becomes difficult when hazardous materials are generated during welding.	제한적 재사용 limited re-use	반영구적 재사용 Semipermanent re-use
	신 공법 New method 재사용이 가능한 친환경적 제품 Environmentally friendly products for re-use.	설계변경에 자유롭다 Free to design changes	

# CT-Joint Proposal



## 개요 / Overview



진공 및 배기 배관에 쓰이는 접합 공법으로, 기존기술의 한계인 현장 용접을 극복한 것으로 관을 절단하여 바로 연결할 수 있고 철거 시 재사용할 수 있는 배관 연결 자재임. 특히 코팅 배관의 용접이 불가능 하거나 후가공이 어려운 곳에 용이하며, 연결이 간편하여 공기 단축 및 원가 절감에 효과적임.

A joint construction method used in vacuum and exhaust piping, which will overcome field welding, one of the limits of the existing technology, can be directly connected by cutting a pipe. A material used in the method will be reusable after it is removed. In particular, the method is very suitable for difficult places about coating piping welding and post-processing. Joints have an excellent resistance to corrosion and thanks to easy connectivity, they are highly effective in reducing construction time and costs.

## 적용범위 / Scope

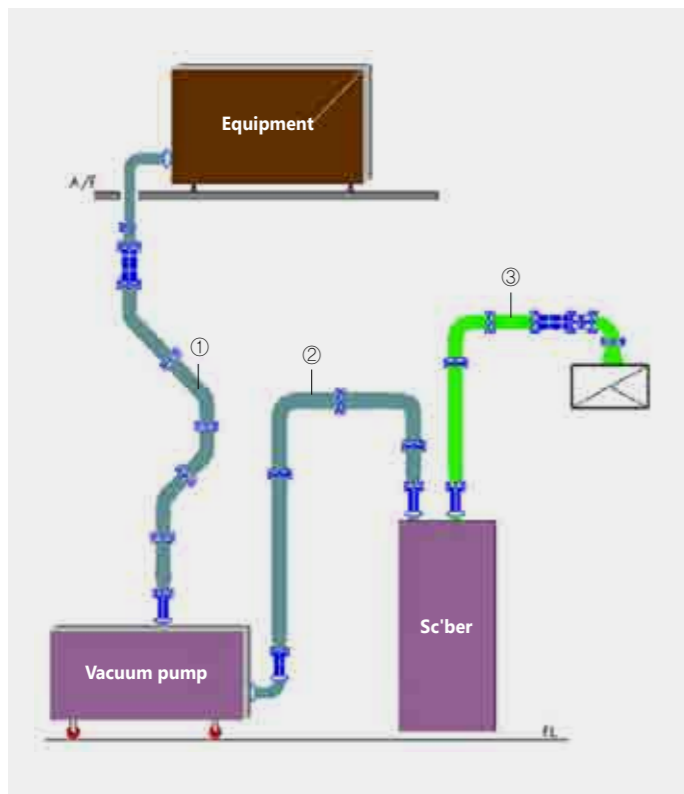

- **非코팅용**
  - ① 진공 LINE, A1-Joint 비코팅용 적용
  - ② 배기 LINE, A1-Joint 비코팅용 적용
- **코팅용**
  - ③ 부식 LINE은 제품에 불소수지 코팅하여, CT-Joint 코팅 적용
- **For the uncoated**
  - ① vacuum LINE, application for A1-Joint non-coated
  - ② exhaust LINE, application for A1-Joint non-coated
- **For coatings**
  - ③ CT-Joint coating is applied to corrosion LINE by coating fluoropolymer

# Fundamental Structure



## 부식 현상 해결 / Resolution for Corrosion



PIPE를 절단하여 ELBOW에 COUPLING을 삽입 후 CLAMP로 결합하여 연결함.  
Coupling inserted at elbow by cutting a pipe is joined with clamp to be connected.

조립식 공법, 무용접 방식으로 체결  
Prefabricated construction method.  
Non-welded crystallization.

## 용접이 필요없는 관의 연결 조인트 / Connecting joints of piping which does not need welding

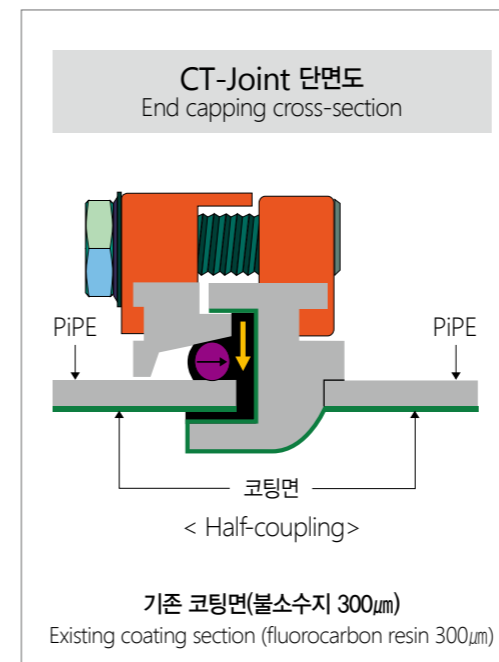

**초기체결 / Initial crystallization**  
체결 시에 압축 링은 패킹과 내재된 압축하여 기밀과 이탈을 방지하게 됨  
In Crystallization, the compression ring prevents airtightening and deviation through the pressure inherent in the packing.

**부압작용 시 / In negative pressure working**  
1차적 팽림현상은 전가되고, 내재된 스텐볼 및 절편은 Fc방향으로 패킹을 더욱 압박하여 강력한 기밀효과를 얻을 수 있게 됨  
As the 1st absorption phenomenon passes on, further pressure from stainless steel balls and fragments on the packing toward Fc leads to powerful airtight effects.

**정압작용 시 / In static pressure**  
배관 내 압력 상승에 의해 관은 Fa 방향으로 빠지게 되고, 패킹에 내재된 스텐볼은 관과 압축링의 경사부에 박히는 썬기구조로 관이 빠질수록 경사부에 스텐볼이 더욱 더 박혀 체결력을 얻을 수 있게 됨  
In-line pressure rise causes the tube to fall toward Fa, and the stainless steel ball inherent in the packing has a wedge structure driven into the slanted area of the tube and compression ring, therefore the more the tube falls, the more the stainless steel ball is driven into the slanted area, leading to crystallization power.

# Operation method



## 작업방법 / Working Method

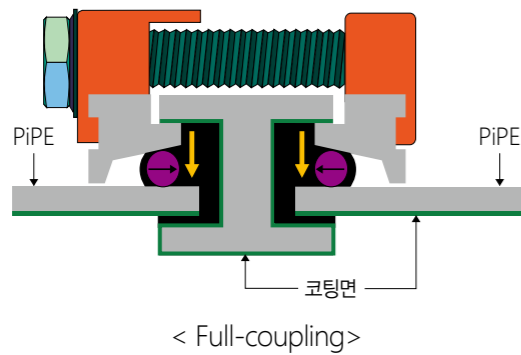
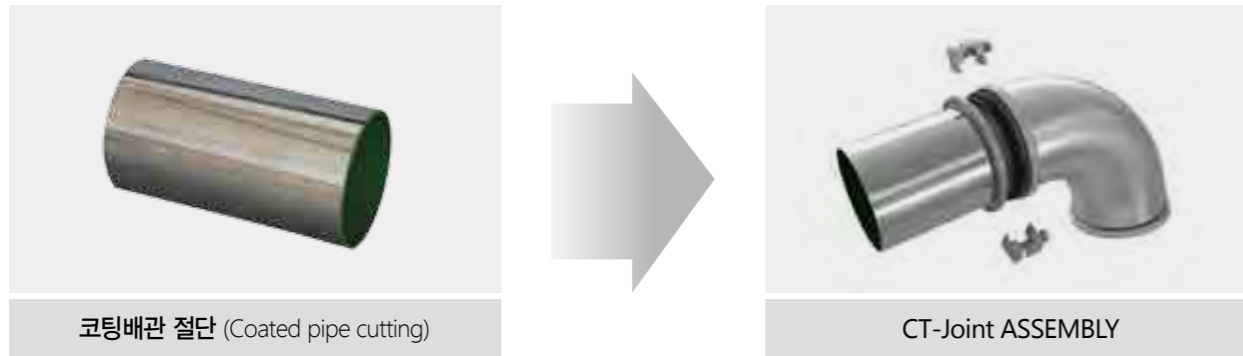

**CT-Joint 단면도**  
End capping cross-section  
기존 코팅면(불소수지 300 $\mu$ m)  
Existing coating section (fluorocarbon resin 300 $\mu$ m)

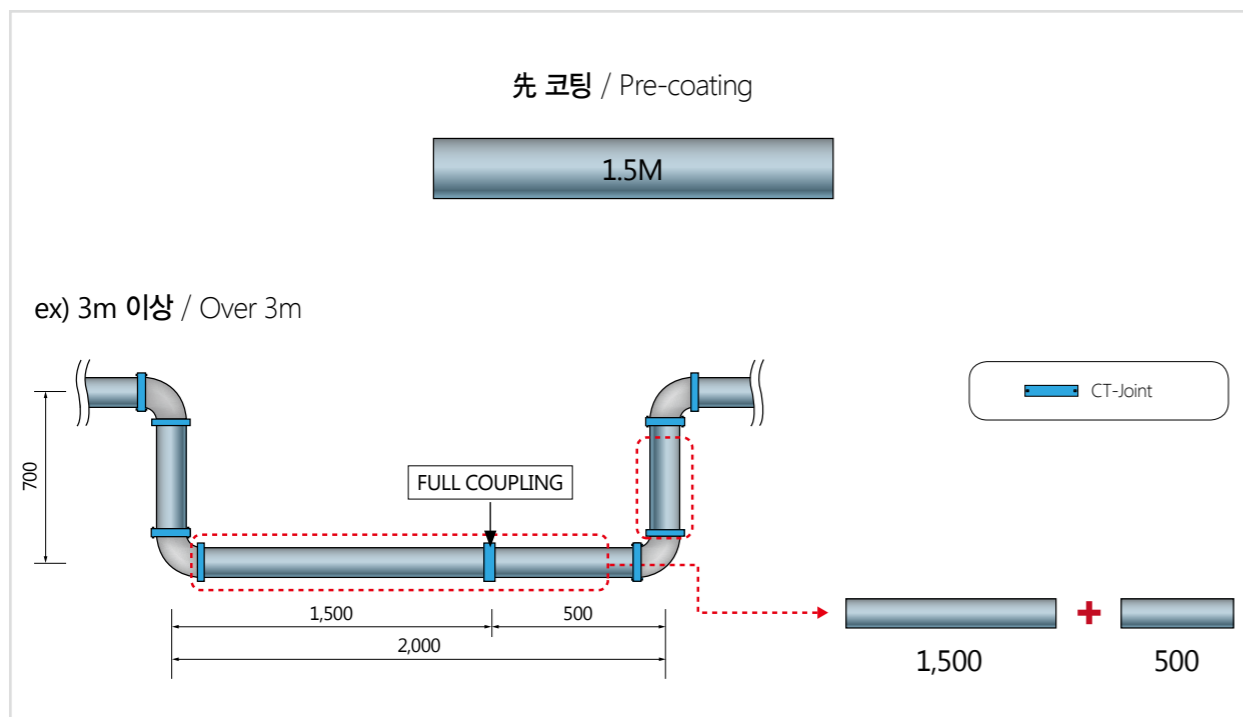

# Work Process



## 작업과정 / Work Process

**코팅자재 입고**  
(Teflon 系)  
Pre-coating  
(Teflon system)  
재질 : 배관용(A) TUBE SIZE (ETFE 코팅)別  
배관 : 두께 2mm , 길이 1.5m  
Material: For pipes (A) per tube size (ETFE coating)  
Pipe: Thickness 1.5mm , Length 1.5m

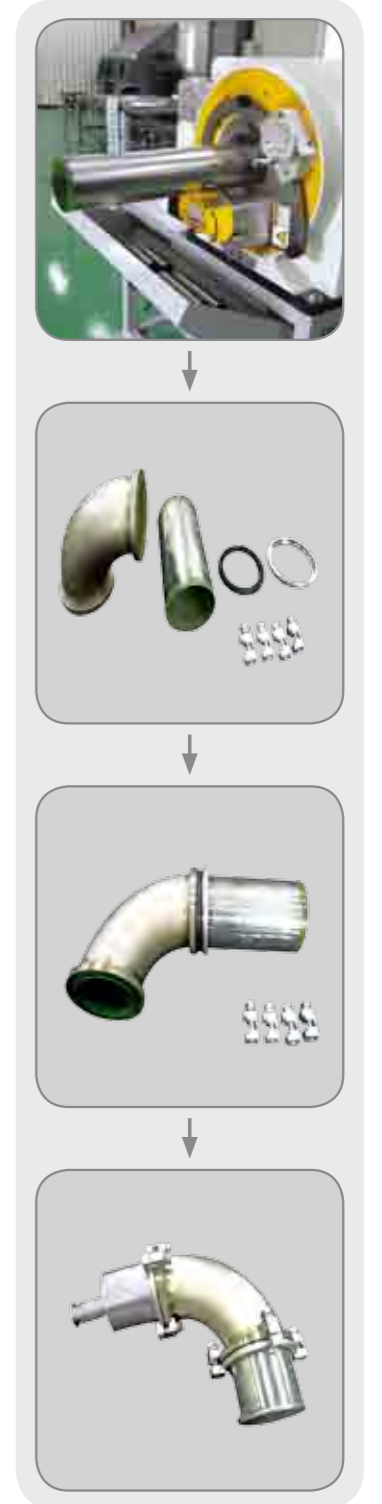

# CT-Joint 시험결과/Proof



## CT-Joint 시험결과 / Test Results

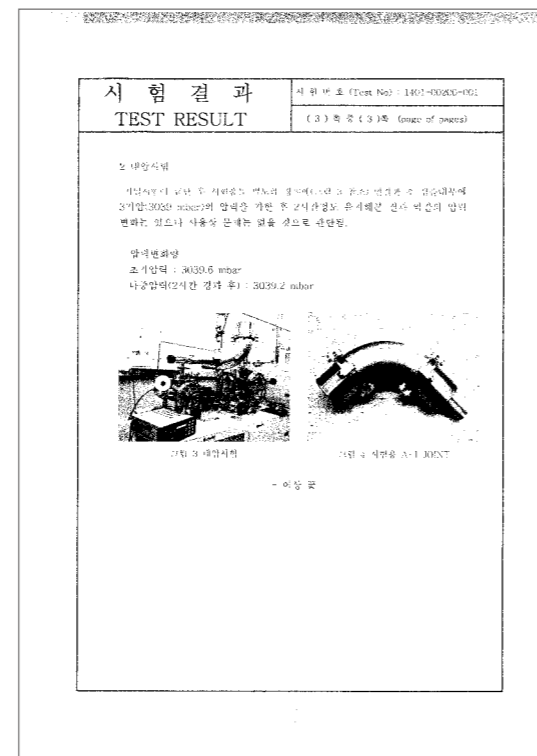
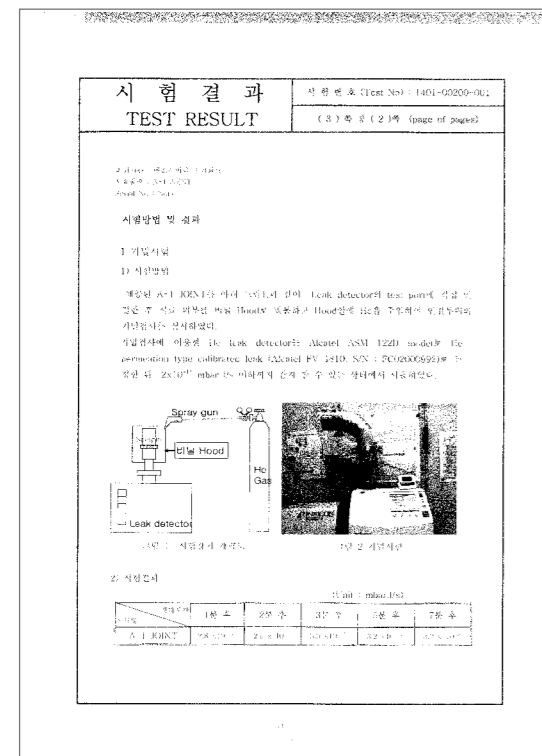
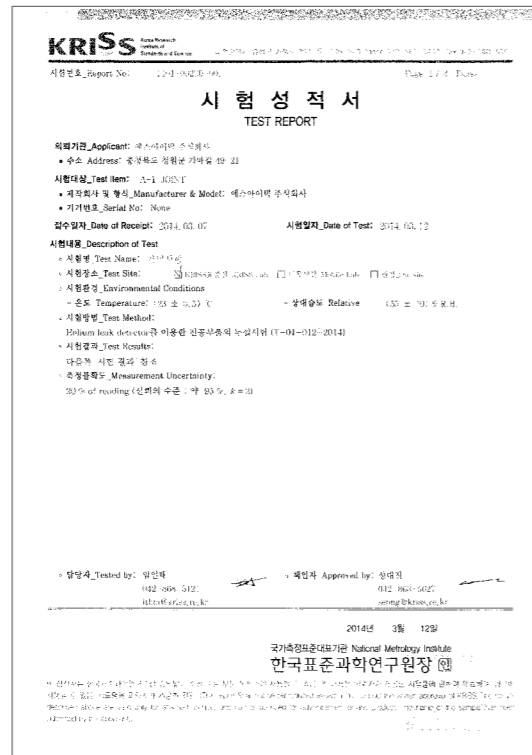

# A1-Joint (진공배관용 FLANGE)



## A1-Joint 구조 / A1-JOINT structure

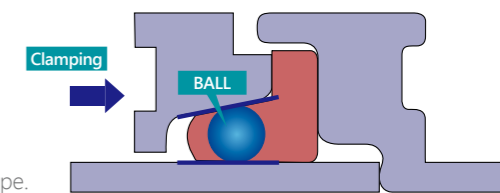
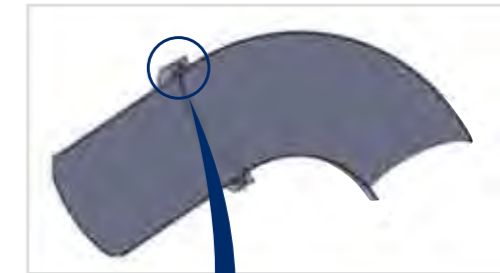
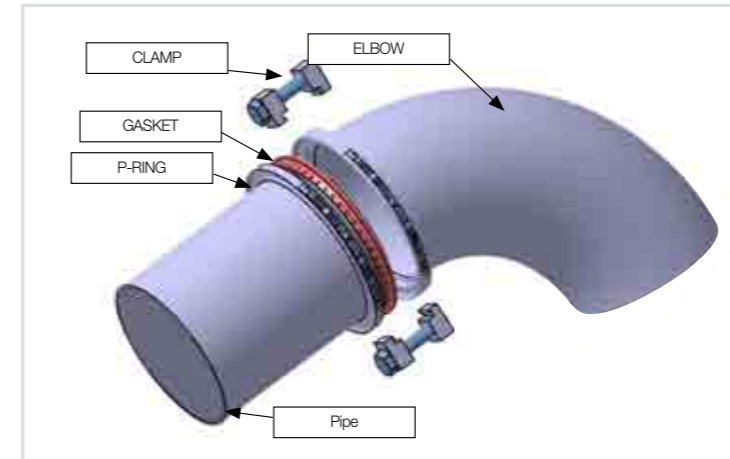

- Gasket 안쪽에 삽입되어 있는 볼이 P-ring과 Pipe를 잡아주는 구조로 되어 있음.
- 볼이 P-ring 부분의 경사면의 좁은 쪽으로 조립 되면서 박히게 되는 원리.
- A ball inserted into a gasket was designed to hold a P-ring and a pipe.
- The principle is that a ball is assembled on the narrow side of the P-ring's slope.

## LINE에 전달되는 진동 / Vibration transmitted to the Line

D/C	A1
<p><b>진동전달로 인한 풀림 현상</b> Unscrewing due to transmitted vibration</p>	<p><b>Joint 부위의 진동 흡수 효과, Joint 부위를 지날수록 진동이 약해짐</b> Vibration is absorbed at the joint. Vibration decreases through the joint.</p>
<p><b>진공펌프의 진동으로 LINE을 타고 생산 장비까지 진동이 전달됨</b> Vibration from a vacuum pump is transmitted to production facilities through lines.</p>	<p><b>풀림 현상 없음</b> No unscrewing</p>
<p><b>CLAMP 풀림 현상</b> Unscrewing CLAMP</p>	<p><b>* S사의 사용 후 결과임</b> * Result after the use of S company</p>

## 굽힘하중 / Bending load

D/C	A1
<p><b>200KGF</b></p>	<p><b>312KGF</b></p>
<p><b>200KGF</b></p>	<p><b>312KGF</b></p>
<p><b>200kgf 하중 시 LEAK 발생</b> Leak at 200kgf load</p>	<p><b>312kgf 하중 시 굽힘은 있으나 LEAK 없음</b> 312kgf load has not leak but bend</p>

# A1-Joint Proposal



## 시공성의 차이점 / Differences in construction

D/C FLANGE	
	<b>용접 POINT가 2개소이다.</b> There are two welding points.
	<b>정확한 거리 실측 요구함.</b> Accurate distance is necessary to measure.
	<b>PIPE와 FLANGE의 직각도 유지</b> A pipe and a flange should meet at right angles to each other.
	<b>REVISION시 FLANGE 재사용 불가</b> No reuse is allowed for a flange in the case of revision.
A1-Joint	
	<b>용접 POINT가 1개소이다.</b> There is one welding point.
	<b>다소 오차범위 허용(±2mm)</b> The margin of error is plus or minus 2mm.
	<b>직각도 유지 오차범위 허용</b> The margin of error allows for maintaining right angles.
	<b>REVISION시 PIPE 직관부 절단만으로 작업이 용이하다.</b> Easy task only with cutting a straight part of piping in the case of revision.

## 진공도 / Degree of vacuum

D/C FLANGE	
	<b>정압시험 2kgf/cm<sup>2</sup> 시 가스켓 이탈(방제시험 연구소)</b> Separated gasket at 2kgf/cm <sup>2</sup> during a static pressure test. (the Fire Insurers Laboratories of Korea)
	<b>진공압 시험 1분 후 LEAK 발생</b> Leak in a minute after a vacuum test.
	<b>충격 압력 LEAK 발생</b> Leak by impact pressure.
	<b>* 방제 시험연구소 자료첨부</b> * Attached is data from the Fire Insurers Laboratories of Korea.
A1-Joint	
	<b>5kgf/cm<sup>2</sup> LEAK 없음</b> No leak at 5kgf/cm <sup>2</sup>
	<b>LEAK 없음</b> No leak.
	<b>진동흡수로 용접부 Crack 없음</b> No crack at welding points thanks to absorbed vibration.

# A1-Joint 시험결과/Proof



## 표준과학 / Standards and Science

	시료명	시험 결과 (경과시간)		
		1분	3분	5분
기존 제품 (N.W & D.C FL'G)	N.W 50	$\leq 2.0 \times 10^{-10}$	$2.5 \times 10^{-10}$	$2.9 \times 10^{-10}$
	D.C 80	$\leq 2.0 \times 10^{-10}$	$2.1 \times 10^{-10}$	$2.3 \times 10^{-10}$
	D.C 100	$\leq 2.0 \times 10^{-10}$	$2.4 \times 10^{-10}$	$2.6 \times 10^{-10}$
A1-JOINT	A.S 50	$\leq 2.0 \times 10^{-10}$	$\leq 2.0 \times 10^{-10}$	$\leq 2.0 \times 10^{-10}$
	A.S 80	$\leq 2.0 \times 10^{-10}$	$\leq 2.0 \times 10^{-10}$	$\leq 2.0 \times 10^{-10}$
	A.S 100	$\leq 2.0 \times 10^{-10}$	$\leq 2.0 \times 10^{-10}$	$\leq 2.0 \times 10^{-10}$

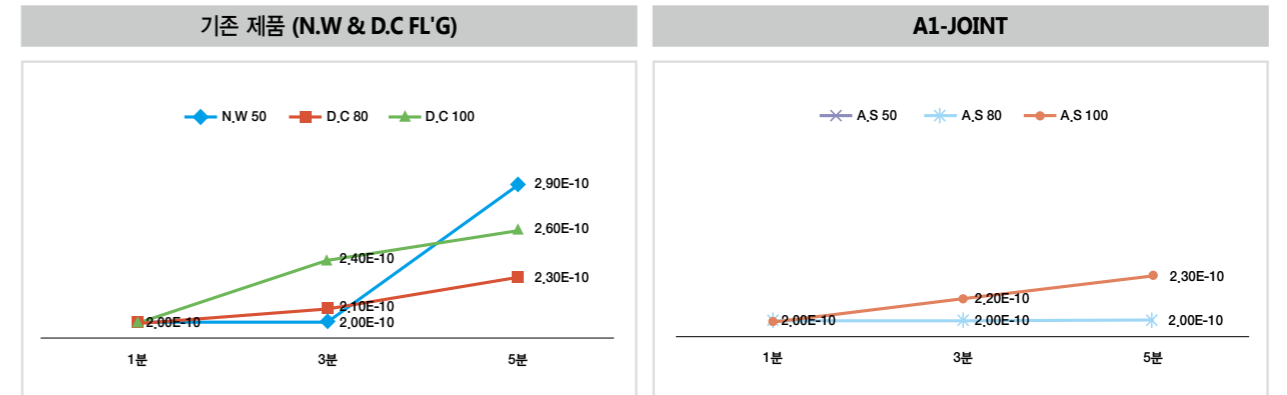

기존 제품보다 진공도가 탁월함.  
Better vacuum than existing products.

## 성적서 / Certificate of Analysis



# OMF-FLANGE Proposal



## 개요 / Overview



OMF-FLANGE를 기존 MF FLANGE를 개선한 것으로 O-RING을 고정하기 위해 센터링인 내링과 외링 없이 O-RING 만으로 견고성을 높이고 원가를 절감할 수 있다.

OMF-FLANGE which was improved from MF FLANGE can increase the robustness and reduce the cost by only the O-RING without the center(inner ring & outer ring) for fixing O-RING.

## 적용범위 / Scope

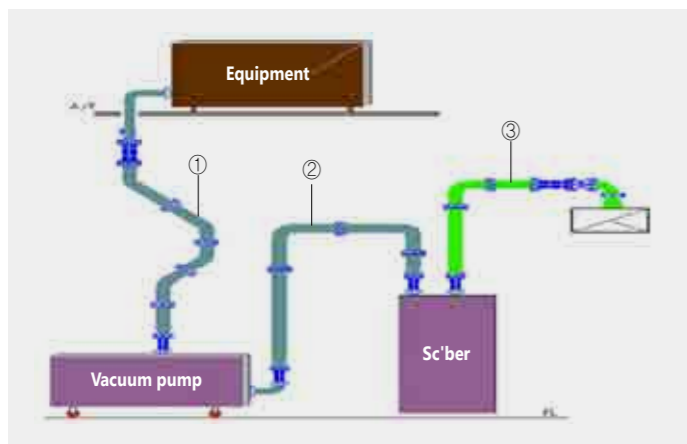

- **非코팅용**
  - ① 진공 LINE, OMF-Joint 비코팅용 적용
  - ② 배기 LINE, OMF-Joint 비코팅용 적용
- **코팅용**
  - ③ 부식 LINE은 제품에 불소수지 코팅하여, CT-Joint 적용
- For the uncoated
  - ① vacuum LINE, application for OMF-Joint non-coated
  - ② exhaust LINE, application for OMF-Joint non-coated
- For coatings
  - ③ CT-Joint coating is applied to corrosion LINE by coating fluoropolymer

## 적용방법 / Application Method



# OMF-FLANGE 시험결과/Proof



## OMF-FLANGE 시험결과 / Test Results

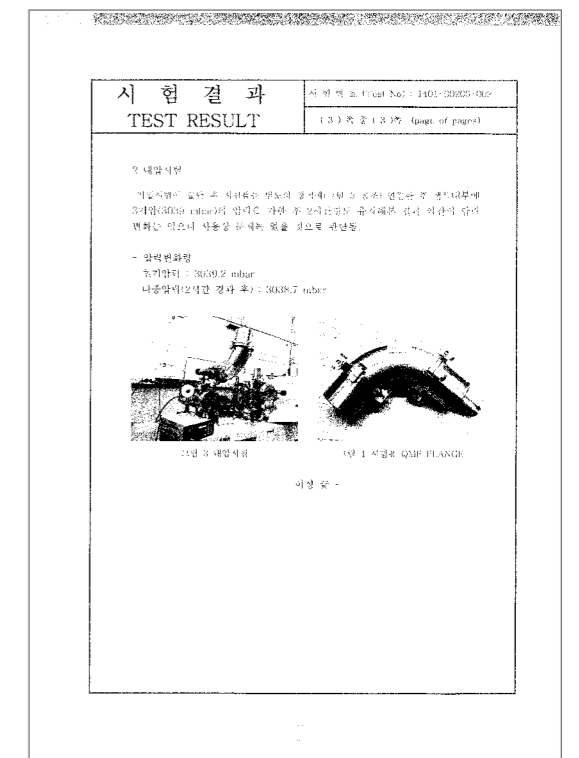
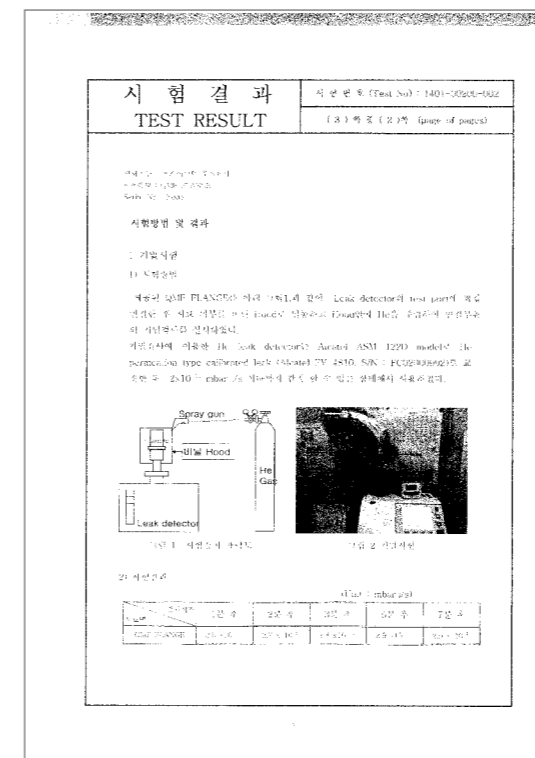
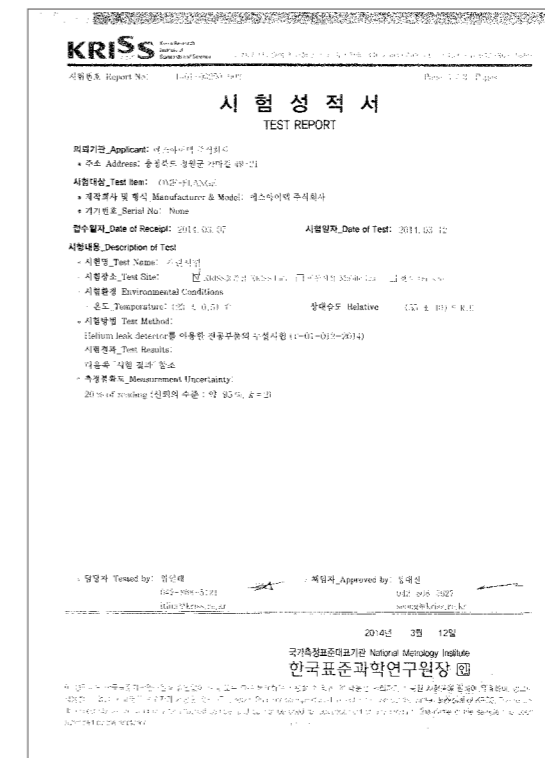

# A2 JOINT Proposal



## 개요 / Overview



현재 반도체, 화학, LCD 배기 LINE 설치시 배관시공 방법으로 FLANGE 용접 방식을 사용하고 있다. 이러한 방법은 비용과 작업시간이 부담스러운 면이 있다. A2-JOINT는 자체비는 물론, 인건비의 절감 효과를 볼 수 있으며 작업시간의 단축으로 생산성이 높으며 유지보수를 쉽게 할 수 있다.

At present, the flange welding method is being practiced as a means to assemble piping for semiconductor, chemical, and LCD ventilation line installation. However, the cost and work duration as a result of using this method is a burden. In contrast, the A2-Joint is effective, not only for the reduced labor cost, but also the material cost. In addition, A reduced work time, results in high productivity and easy maintenance.

## 적용범위 / Scope

종류 Type	재질 Material	SUS	SPP	SPPW	Copper Pipe	PVC	안전성 Safety
배기 Ventilation		○	○	○	○	○	무용접 작업으로 화재사고 및 추락사고 방지 No welding prevents fires and falls
배수 Discharge		○	○	○	○	○	모든 자재 재사용 가능 All materials can be reused
최대사용 압력 Maximum used pressure		정압 : 3kgf/cm <sup>2</sup> 부압 : 2.0x10 <sup>-10</sup> torr					공기단축 및 고인력 불필요로 인한 인건비 절감 시공시 부대비용 절감효과 Reduced construction time and elimination of the need for highly skilled workers saves on labor costs and effective in reducing incidental expenses during construction
							관내 신축이음의 효과를 볼 수 있게 설계되어 진동으로 인한 건물의 훼손 방지 및 장비의 수명 연장 효과 Expansion joint inside the pipe is designed to produce positive results such as prevention of building damages from vibration and prolonged equipment life cycle

## 적용방법 / Application Method

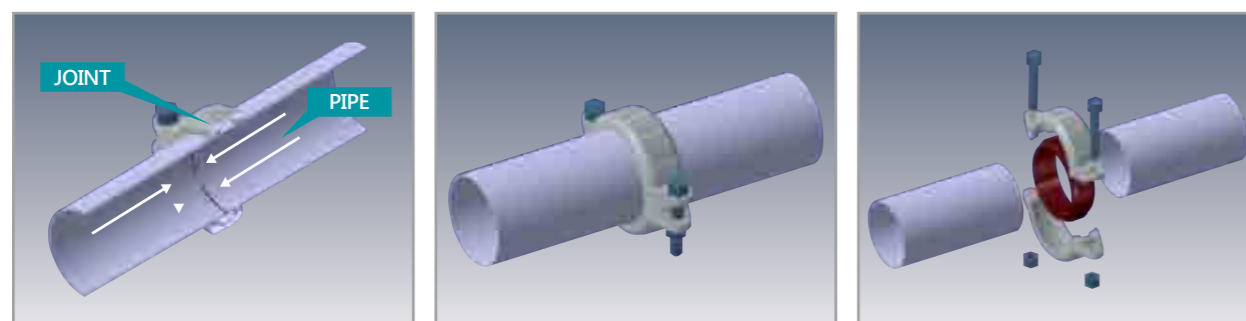

# A3 JOINT Proposal



## 개요 / Overview



본 제품은 모든 설비배관에 적용 가능하며 시공이 간편하고, 재사용이 가능하므로 원가절감은 물론 환경 및 화기로부터의 안전에도 탁월한 효과를 볼 수 있다.

This product is applicable to every kind of equipment piping, and convenient in construction. In addition, it can be re-used, so that it is effective not just for saving costs but for the environment and safety from flammable items.

## 적용범위 / Scope

종류 Type	재질 Material	SUS	SPP	SPPW	Copper Pipe	PVC	안전성 Safety
급수 Water Supply		○	○	○	○	○	무용접 작업으로 화재사고 및 추락사고 방지 No welding prevents fires and falls
급탕 Hot Water		○	○	○	○	○	모든 자재 재사용 가능 All materials can be reused
냉난방 Heating/Cooling		○	○	○	○	○	공기단축 및 고인력 불필요로 인한 인건비 절감 시공시 부대비용 절감효과 Reduced construction time and elimination of the need for highly skilled workers saves on labor costs and effective in reducing incidental expenses during construction
소방 배관 firefighting pipe		○	○	○	○	○	관내 신축이음의 효과를 볼 수 있게 설계되어 진동으로 인한 건물의 훼손 방지 및 장비의 수명 연장 효과 Expansion joint inside the pipe is designed to produce positive results such as prevention of building damages from vibration and prolonged equipment life cycle
최대사용 압력 Maximum used pressure		15kgf/cm <sup>2</sup>				10kgf/cm <sup>2</sup>	

## 적용방법 및 구조 / Application Method and Structure

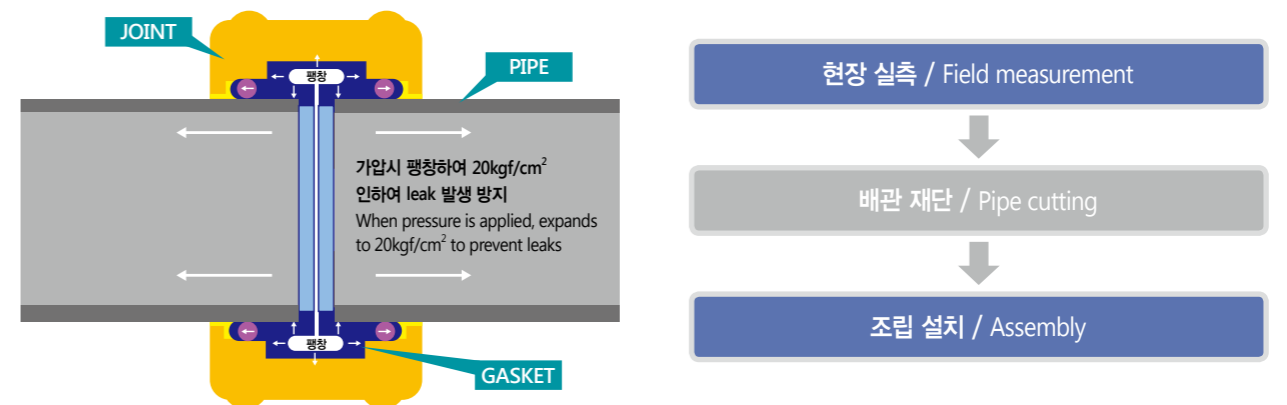

# LOCK-Joint



## 개요 / Overview



LOCK-Joint는 용접 작업이 어려울 때 pipe만 절단하여 Jointing 하는 방식으로 장비의 PCW(냉각수)LINE 작업에 많이 사용되는 Tube Lock Pitting과 흡사하며 pipe 용 Lock-Joint이다.

LOCK-Joint is the method in which jointing is conducted by cutting only pipe when welding is difficult, it is similar to Tube Lock Pitting and is a Lock-Joint for pipes.

## 적용범위 / Scope

종류 Type	재질 Material	SUS 304	SPP	SPPW	Copper Pipe	PVC	안전성 Safety
PCW		○	○	○	○	○	무용접 작업으로 화재사고 및 추락사고 방지 No welding prevents fires and falls
시수, 공수		○	○	○	○	○	재사용 Reusable 모든 자재 재사용 가능 All materials can be reused
최대사용 압력 Maximum used pressure		15kgf/cm <sup>2</sup>				10kgf/cm <sup>2</sup>	비용절감 Cost reduction 공기단축 및 고인력 불필요로 인한 인건비 절감 시공시 부대비용 절감효과 Reduced construction time and elimination of the need for highly skilled workers saves on labor costs and effective in reducing incidental expenses during construction
							진동흡수 Vibration absorption 관내 신축이음의 효과를 볼 수 있게 설계되어 진동으로 인한 건물의 훼손 방지 및 장비의 수명 연장 효과 Expansion joint inside the pipe is designed to produce positive results such as prevention of building damages from vibration and prolonged equipment life cycle

## 적용방법 / Application Method



# INLET VALVE



## 바닥형 / Floor Type

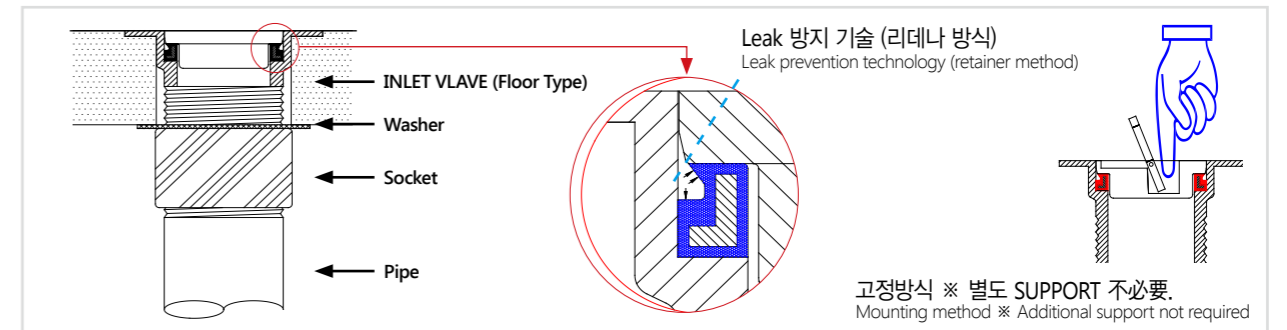

설치 조립도(Access Floor 조립) / Installation assembly drawing (Access Floor assembly)

## 벽부형 / Wall Type

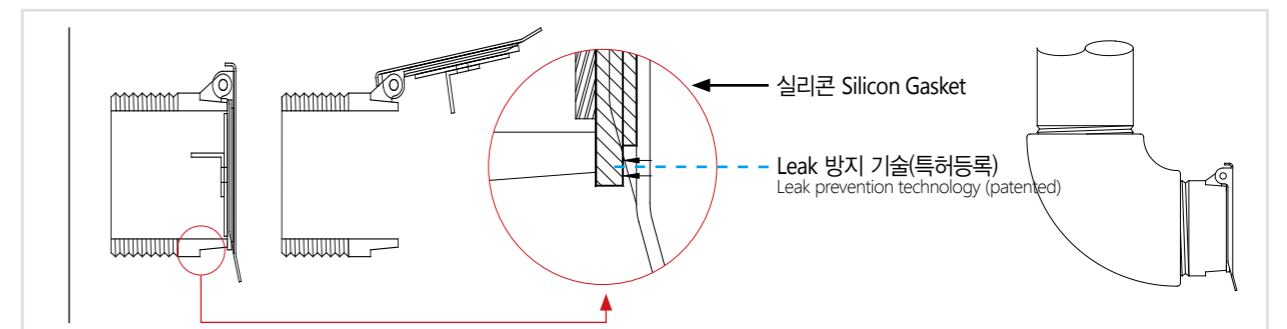

설치 조립도(Access Floor 조립) / Installation assembly drawing (Access Floor assembly)

# ROUND VOLUME DAMPER(SUS)



## 개요 / Overview

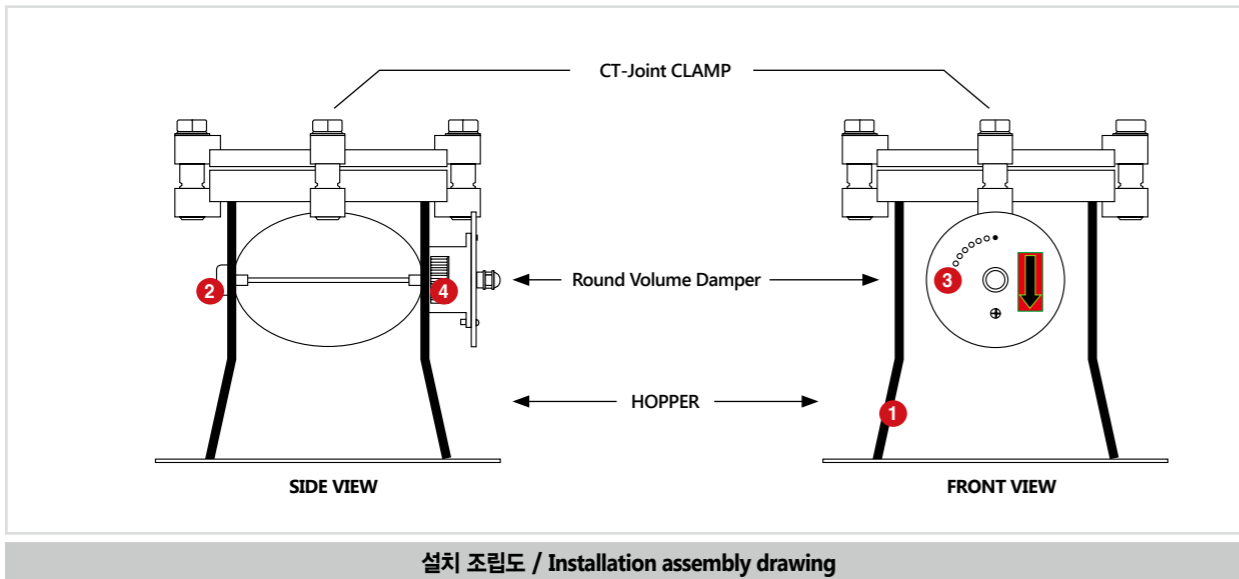

- ① 제살로 확관. 용접 Point가 없고 Hopper 겸용
  - ② 제살로 요철하여 용접 / Leak Point가 없다
  - ③ Shut->Open까지 8단계로 미세 조정이 가능하며 자동 잠금 장치로 오작동 해소
  - ④ 내부 Packing 처리로 Leak가 없다
- ① Autogenous pipe expansion. No welding point and is used in conjunction with the hopper.
  - ② Autogenous ribs eliminates welding and leak points.
  - ③ 8 stages exist from SHUT to OPEN, enabling fine adjustments, and an auto locking device alleviates malfunctions.
  - ④ Inner packing process leads to no leakage.

# Product Type



## CT-Joint : HALF-COUPLING(SUS304)



구분	SIZE	A	B	t(폭)
배관 (A-SIZE)	50A	81.1	50.1	14
	80A	109.7	78.7	
	100A	134.9	103.9	
	125A	160.4	129.4	
	200A	236.9	205.9	
구조관 (TUBE)	250A	288	257	14
	50A	71.4	40.4	
	80A	96.8	65.8	
	100A	122.2	91.2	
	125A	147.6	116.6	
150A	173	142		

## CT, A1-Joint : P-RING(SUS304)



구분	SIZE	A	B	t(폭)
배관 (A-SIZE)	50A	80.5	62.1	11
	80A	109.1	90.7	
	100A	134.3	115.9	
	125A	160.80	142.0	
	200A	237.29	218.5	
구조관 (TUBE)	250A	288.40	269.6	11
	50A	70.8	52.4	
	80A	96.2	77.8	
	100A	121.6	103.2	
	125A	148.0	129.2	
150A	173.40	154.6		

## CT-Joint : GASKET(EPDM)

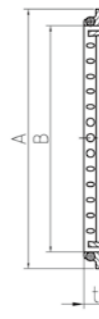

구분	SIZE	A	B	t(폭)
배관 (A-SIZE)	50A	75.5	60.5	10.5
	80A	104.1	89.1	
	100A	129.3	114.3	
	125A	154.8	139.8	
	150A	180.2	165.2	
구조관 (TUBE)	200A	231.3	216.3	10.5
	250A	282.4	267.4	
	50A	65.8	50.8	
	80A	91.2	76.2	
	100A	116.6	101.6	
125A	142	127		
150A	167.4	152.4		

## CT-Joint : FULL-COUPLING(SUS304)



구분	SIZE	A	B	t(폭)
배관 (A-SIZE)	50A	81.1	50.1	19
	80A	109.7	78.7	
	100A	134.9	103.9	
	125A	160.4	129.4	
	150A	185.8	154.8	
구조관 (TUBE)	200A	236.9	205.9	19
	250A	288	257	
	50A	71.4	40.4	
	80A	96.8	65.8	
	100A	122.2	91.2	
125A	147.6	116.6		
150A	173	142		

# Product Type



CT-Joint : ELBOW90°(SUS304)

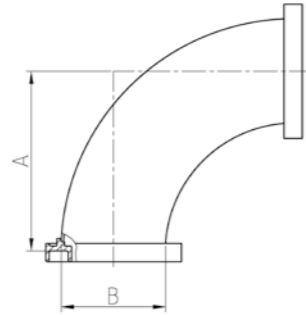
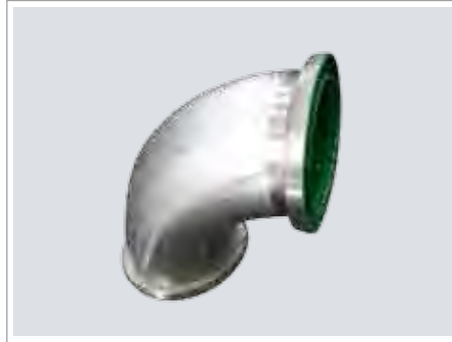

구분	SIZE	A	B
배관 (A-SIZE)	50A	83.7	60.5
	80A	121.8	89.1
	100A	159.9	114.3
	125A	198	139.8
	150A	236.1	165.2
	200A	312.3	216.3
구조관 (TUBE)	250A	388.5	267.4
	50A	83.7	50.8
	80A	121.8	76.2
	100A	159.9	101.6
	125A	198	127.0
150A	236.1	152.4	

CT-Joint : ELBOW45°(SUS304)

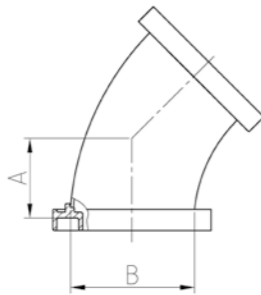

구분	SIZE	A	B
배관 (A-SIZE)	50A	39.1	60.5
	80A	54.8	89.1
	100A	70.6	114.3
	125A	86.4	139.8
	150A	102.2	165.2
	200A	133.8	216.3
구조관 (TUBE)	250A	165.3	267.4
	50A	39.1	50.8
	80A	54.8	76.2
	100A	70.6	101.6
	125A	86.4	127.0
150A	102.2	152.4	

CT-Joint : TEE(SUS304)

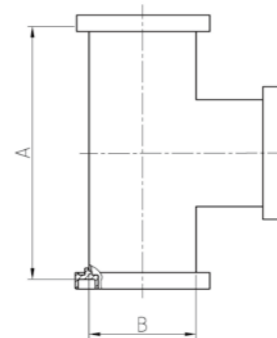

구분	SIZE	A	B
배관 (A-SIZE)	50A	142	60.5
	80A	186.4	89.1
	100A	224.6	114.3
	125A	262.6	139.8
	150A	300.8	165.2
	200A	370.6	216.3
구조관 (TUBE)	250A	446.8	267.4
	50A	142	50.8
	80A	186.4	76.2
	100A	224.6	101.6
	125A	262.6	127.0
150A	300.8	152.4	

CT-Joint : REDUCER(SUS304)

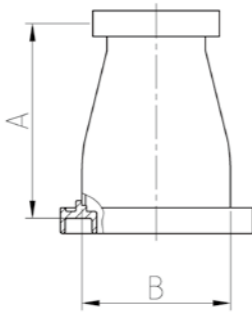

구분	SIZE	A	B
배관 (A-SIZE)	50A	91.2	60.8
	80A	103.9	89.1
	100A	116.6	114.3
	125A	142	139.8
	150A	154.7	165.2
	200A	167.4	216.3
구조관 (TUBE)	250A	192.8	267.4
	50A	91.2	50.8
	80A	103.9	76.2
	100A	116.6	101.6
	125A	142	127.0
150A	154.7	152.4	

# Product Type



A1-Joint : HALF-COUPLING(SUS304)



구분	SIZE	A	B	t(쪽)
배관 (A-SIZE)	50A	80.5	56.5	12
	80A	109.1	85.1	
	100A	134.3	110.3	
	125A	160.80	135.8	
	150A	186.19	161.2	
	200A	237.29	210.3	
구조관 (TUBE)	250A	288.40	261.4	
	50A	70.8	46.8	
	80A	96.2	72.2	
	100A	121.6	97.6	
	125A	148.0	123.0	
150A	173.40	148.4		

A1-Joint : GASKET(EPDM)

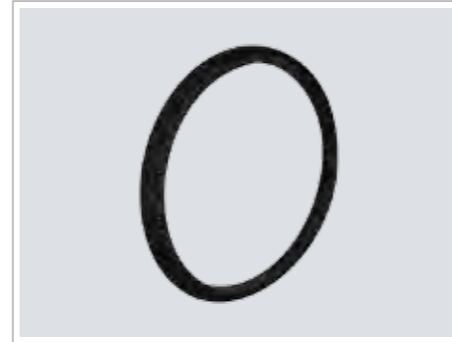

구분	SIZE	A	B	t(쪽)	
배관 (A-SIZE)	50A	75.5	60.5	9.5	
	80A	104.1	89.1		
	100A	129.3	114.3		
	구조관 (TUBE)	125A	156.80	140.00	9.88
		150A	182.19	165.40	
		200A	233.29	216.50	
250A		284.40	267.60		
50A		65.8	50.8		
구조관 (TUBE)	80A	91.2	76.2	9.5	
	100A	116.6	101.6		
	125A	144.0	127.2		
	150A	169.4	152.6		

A1-Joint : ELBOW90° (SUS304)

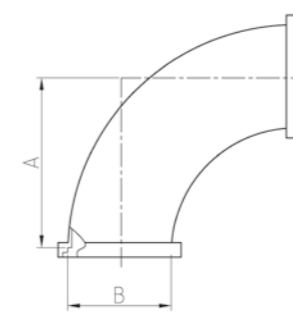

구분	SIZE	A	B
배관 (A-SIZE)	50A	79.2	60.5
	80A	117.3	89.1
	100A	155.4	114.3
	125A	193.5	139.8
	150A	231.6	165.2
	200A	307.8	216.3
구조관 (TUBE)	250A	384.0	267.4
	50A	79.2	50.8
	80A	117.3	76.2
	100A	155.4	101.6
	125A	193.5	127.0
150A	231.6	152.4	

A1-Joint : ELBOW45° (SUS304)

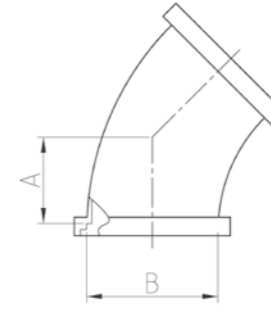

구분	SIZE	A	B
배관 (A-SIZE)	50A	34.6	60.5
	80A	50.3	89.1
	100A	66.1	114.3
	125A	81.9	139.8
	150A	97.7	165.2
	200A	129.3	216.3
구조관 (TUBE)	250A	160.8	267.4
	50A	34.6	50.8
	80A	50.3	76.2
	100A	70.6	101.6
	125A	81.9	127.0
150A	97.7.2	152.4	

# Product Type



OMF : FLANGE (SUS304)



구분	SIZE	A	B	t(폭)
배관 (A-SIZE)	80A	116.7	89.1	9
	100A	141.9	114.3	
	125A	167.4	139.8	
	150A	192.8	165.2	
	200A	243.9	216.3	
구조관 (TUBE)	80A	103.9	76.2	9
	100A	129.6	101.6	
	150A	180	152.4	

OMF : GASKET(VITON)

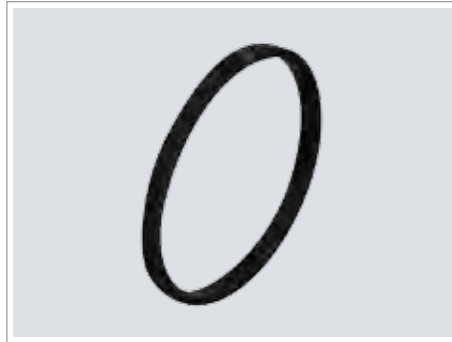

구분	SIZE	A	B	t(폭)
배관 (A-SIZE)	80A	120.1	92.1	8
	100A	127.3	117.3	
	125A	152.8	142.8	
	150A	178.2	168.2	
	200A	229.3	219.3	
구조관 (TUBE)	80A	89.3	79.3	8
	100A	114.6	140.6	
	150A	165.4	155.4	

OMF : ELBOW90°(SUS304)

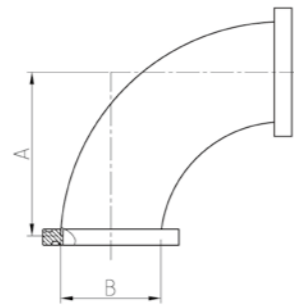

구분	SIZE	A	B
배관 (A-SIZE)	50A	76.2	60.5
	80A	114.3	89.1
	100A	152.4	114.3
	125A	190.5	139.8
	150A	228.6	165.2
	200A	304.8	216.3
구조관 (TUBE)	50A	76.2	50.8
	80A	114.3	76.2
	100A	152.4	101.6
	150A	228.6	152.4

OMF : ELBOW45°(SUS304)

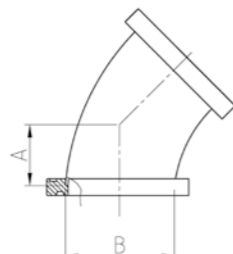

구분	SIZE	A	B
배관 (A-SIZE)	50A	31.6	60.5
	80A	47.3	89.1
	100A	63.1	114.3
	125A	78.9	139.8
	150A	94.7	165.2
	200A	126.3	216.3
구조관 (TUBE) 1.5T~2T	50A	39.1	50.8
	80A	54.8	76.2
	100A	70.6	101.6
	125A	86.4	127.0
	150A	102.2	152.4

# Product Type



PIPE Coating(SUS304)

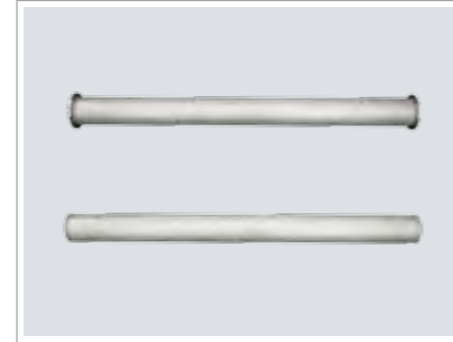

구분	SIZE	A	B
배관 (A-SIZE)	50A	1500	60.5
	80A		89.1
	100A		114.3
	125A		139.8
	150A		165.2
	200A		216.3
구조관 (TUBE) 1.5T~2T	50A	1500	50.8
	80A		76.2
	100A		101.6
	125A		127.0
	150A		152.4

CLAMP(아연도금/Zinc Plating)

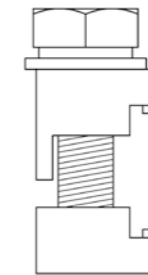

Adapter(SUS304)

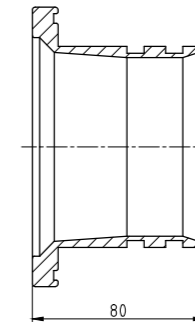

WELDING DAMPER(SUS304)

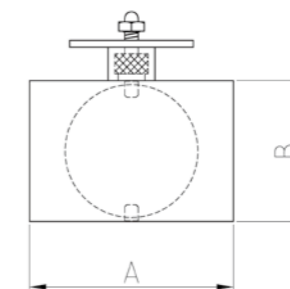
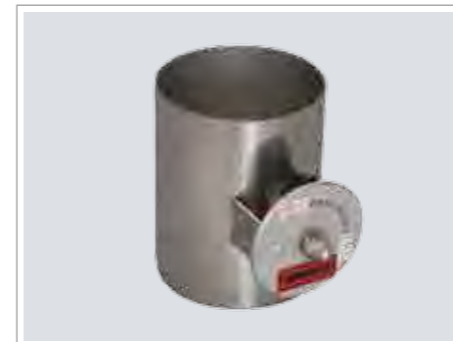

구분	SIZE	A	B
배관 (A-SIZE)	50A	70.5	60.5
	80A	99.1	89.1
	100A	124.3	114.3
	125A	149.8	139.8
	150A	175.2	165.2
	200A	226.3	216.3
구조관 (TUBE) 1.5T~2T	50A	70.5	50.8
	80A	99.1	76.2
	100A	124.3	101.6
	125A	149.8	127.0
	150A	175.2	152.4

# Product Type



CT, A1-Joint : BELLOWS(SUS304)

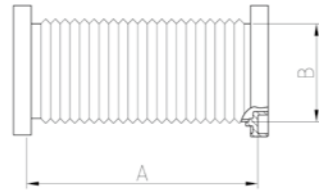

구분	SIZE	A	B
배관 (A-SIZE)	50A	60.5	60.5
	80A	89.1	89.1
	100A	114.3	114.3
	125A	139.8	139.8
	150A	165.2	165.2
구조관 (TUBE)	50A	50.8	50.8
	80A	76.2	76.2
	100A	101.6	101.6
	125A	127.0	127.0
	150A	152.4	152.4

제살접이식 CLAMP(SUS304)

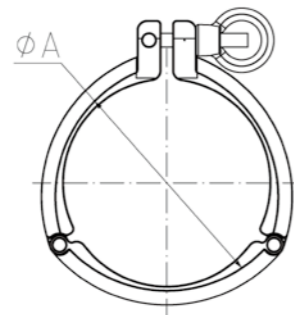

SIZE	A
80A	89.1
100A	114.3
125A	139.8
150A	165.2
200A	216.3
250A	267.4

INLETVALVE (Wall Type)

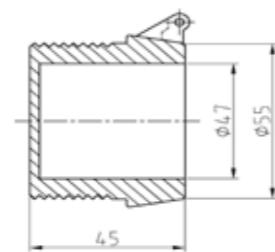

IELETVALVE (Floor Type)

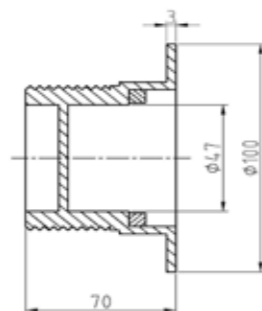

# Product Type



PVC DAMPER(양쪽 Flange)

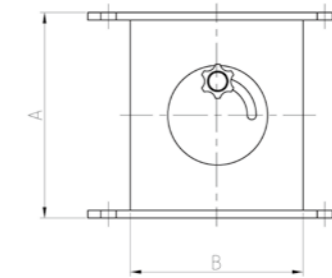

구분	SIZE	A	B
PVC DAMPER 양쪽 FLANGE	50A	60	60
	75A	89	89
	100A	114	114
	125A	140	140
	150A	165	165
200A	216	216	
250A	267	267	

PVC DAMPER(SOKET Type)

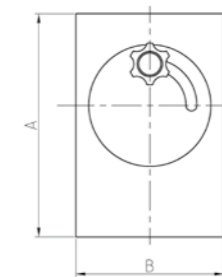

구분	SIZE	A	B
PVC SOKET TYPE	50A	60	60
	75A	89	89
	100A	114	114
	125A	140	140
	150A	165	165
	200A	216	216
	250A	267	267

A2-JOINT

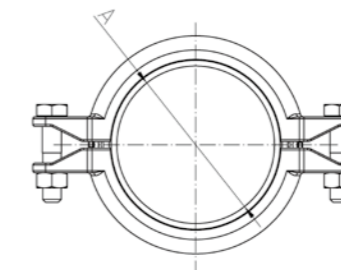

SIZE	A
80A	88.5
100A	113.3
125A	138.8
150A	164.2

A3-JOINT

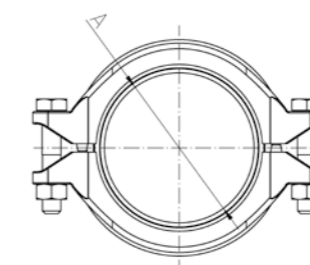

SIZE	A
80A	88.5
100A	113.3
125A	138.8
150A	164.2